

Spatial TIMES

BIBERACHER, Markus
research studios austria, Austria

EDER, Tobias
Max-Planck-Institut für Plasmaphysik, Germany

08.11.2011

BIBERACHER, Markus; RSA [markus.biberacher@researchstudio.at]
EDER, Tobias; IPP [tobias.eder@ipp.mpg.de]

Slide 1

GIS in a nutshell

“A geographic information system (GIS) integrates hardware, software and data for capturing, managing, analyzing, and displaying all forms of geographically referenced information.” – ESRI

- Vectors
 - lines
 - corridors, distribution networks
 - points
 - sites, plants
 - polygons
 - regions, areas in general
- Rasters
 - potentials, climate, POP, GDP, ...
- ArcGIS, MapInfo, Manifold, QGIS...

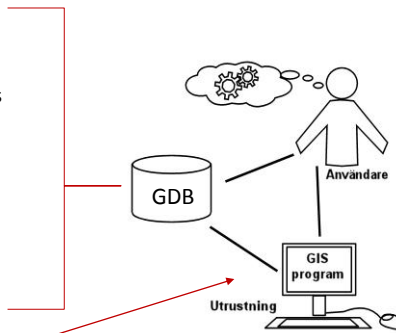

08.11.2011

BIBERACHER, Markus; RSA [markus.biberacher@researchstudio.at]
EDER, Tobias; IPP [tobias.eder@ipp.mpg.de]

Slide 2

“Spatializing” TIMES models

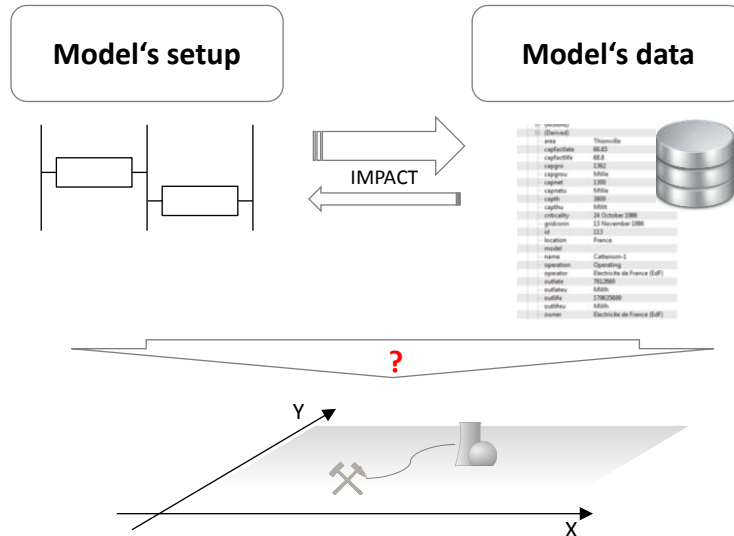

08.11.2011

BIBERACHER, Markus; RSA [markus.biberacher@researchstudio.at]
EDER, Tobias; IPP [tobias.eder@ipp.mpg.de]

Slide 3

Spatial data in energy system models



Example: Global nuclear power plant database (EFDA TIMES)

- flexible regional aggregation of processes and related parameters (type, CAP, RESID, ...)

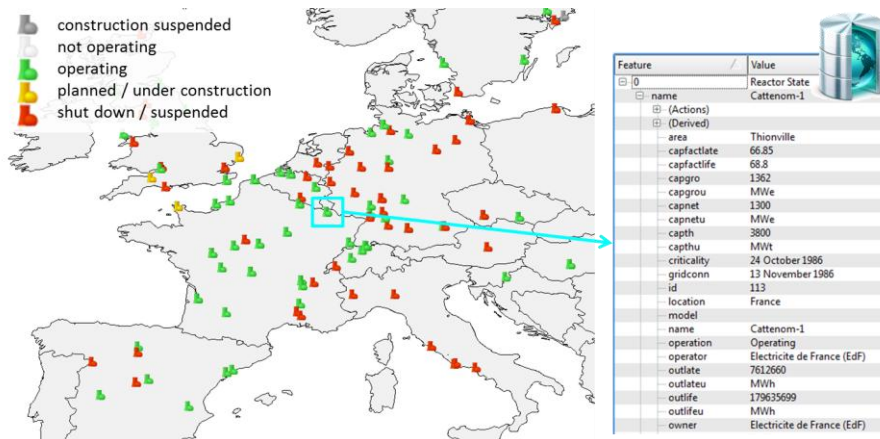

08.11.2011

BIBERACHER, Markus; RSA [markus.biberacher@researchstudio.at]
EDER, Tobias; IPP [tobias.eder@ipp.mpg.de]

Slide 4

Spatial data in energy system models



Example: Global wind power potential (EFDA TIMES)

- flexible regional aggregation of potentials (capacity bounds, efficiency levels ...)
- feedback loops to (spatial) climate models (RES in general)

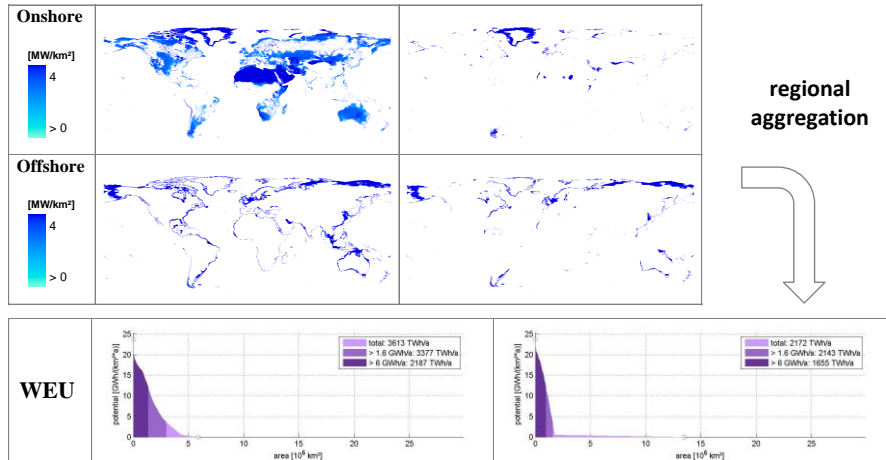

08.11.2011

BIBERACHER, Markus; RSA [markus.biberacher@researchstudio.at]
EDER, Tobias; IPP [tobias.eder@ipp.mpg.de]

Slide 5

Spatial model's structure



Example: "Developing a Roadmap for the Future Energy Infrastructure in Salzburg"

- TIMES-based model, geo-referencing via regions

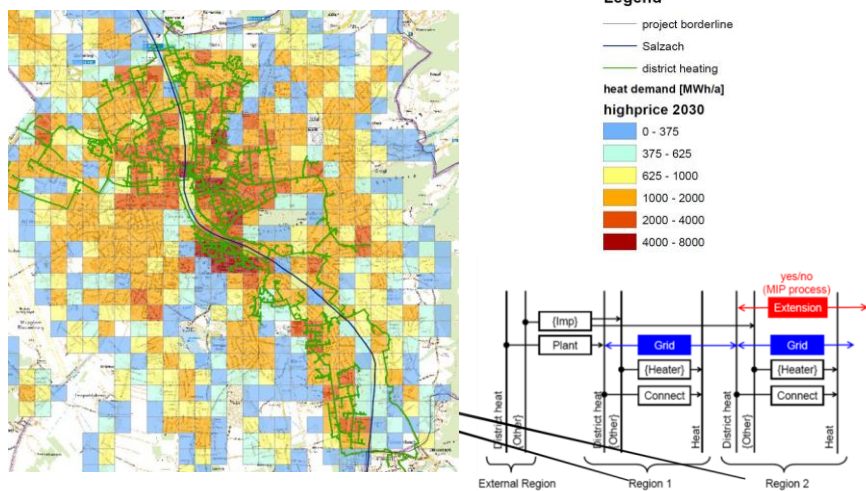

08.11.2011

BIBERACHER, Markus; RSA [markus.biberacher@researchstudio.at]
EDER, Tobias; IPP [tobias.eder@ipp.mpg.de]

Slide 6

Spatial model's structure



Example: Project „RECO2NWK“, Regional optimization of heat supply promoting renewables
 - GAMS model with geo-referenced processes and commodity flows

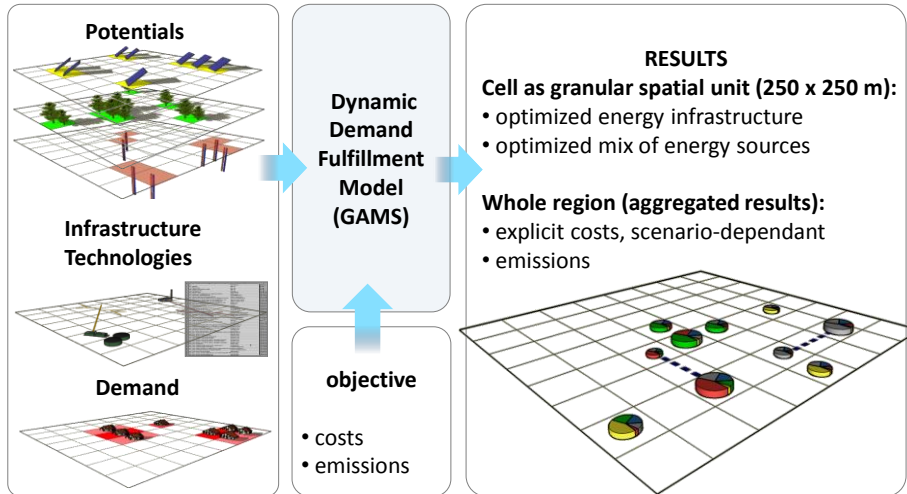

08.11.2011

BIBERACHER, Markus; RSA [markus.biberacher@researchstudio.at]
 EDER, Tobias; IPP [tobias.eder@ipp.mpg.de]

Slide 7

Spatial model's structure



08.11.2011

BIBERACHER, Markus; RSA [markus.biberacher@researchstudio.at]
 EDER, Tobias; IPP [tobias.eder@ipp.mpg.de]

Slide 8

Spatial topology of energy system models



A) SPATIAL TOPOLOGY REPRESENTED BY REGIONS

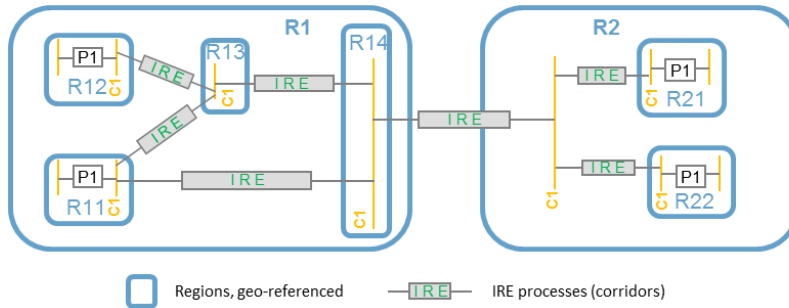

In GIS / GDB: all regional levels represented
In TIMES: lowest level (finest granularity) implemented (aggregation by attribution)

08.11.2011

BIBERACHER, Markus; RSA [markus.biberacher@researchstudio.at]
 EDER, Tobias; IPP [tobias.eder@ipp.mpg.de]

Slide 9

Spatial topology of energy system models



B) SPATIAL TOPOLOGY REPRESENTED BY PROCESSES AND COMMODITIES

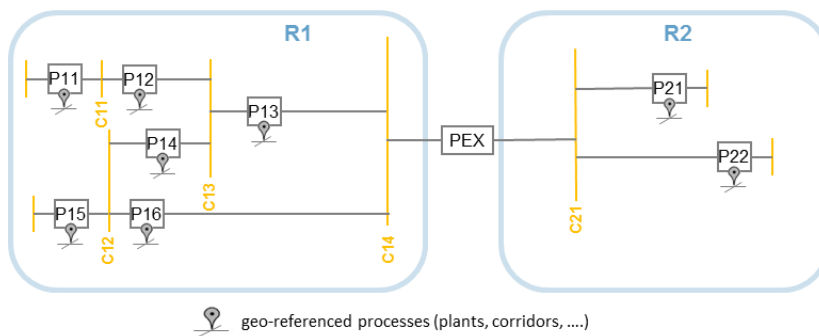

In GIS / GDB: representation of georeferenced processes and regions
In TIMES: regional attribution, georeferencing by process / commodity splitting

08.11.2011

BIBERACHER, Markus; RSA [markus.biberacher@researchstudio.at]
 EDER, Tobias; IPP [tobias.eder@ipp.mpg.de]

Slide 10

Implementation of spatial TIMES models in GDB

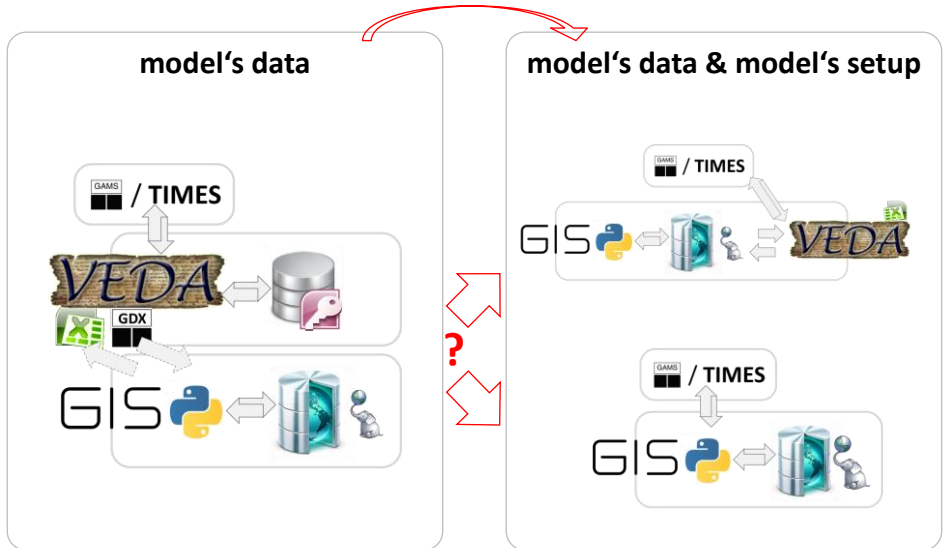

08.11.2011

BIBERACHER, Markus; RSA [markus.biberacher@researchstudio.at]
EDER, Tobias; IPP [tobias.eder@ipp.mpg.de]

Slide 11

Implementation of TIMES in open source GDB

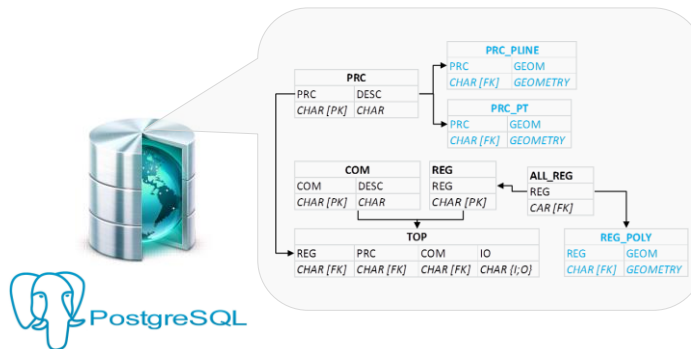

08.11.2011

BIBERACHER, Markus; RSA [markus.biberacher@researchstudio.at]
EDER, Tobias; IPP [tobias.eder@ipp.mpg.de]

Slide 12

Conclusion & Outlook



Actual state

- review on existing applications and implementations
- Investigation of implementation pathways (direct integration / loose coupling ...)
- implementation of TIMES in GDB (current topic)

Tasks to be completed

- finalizing implementation of TIMES in GDB
- implementation of GDB interfaces (GDB2DD and GD2GDB)
- benchmark of spatial model frameworks
- report to ETSAP

General remarks

- participation of community welcome / necessary -> discussion form (?)
- open source database scheme and interfaces provided for download



DISKUSSION

Spatial data in energy system models



Example REACCESS

- spatial visualization of energy corridors / results

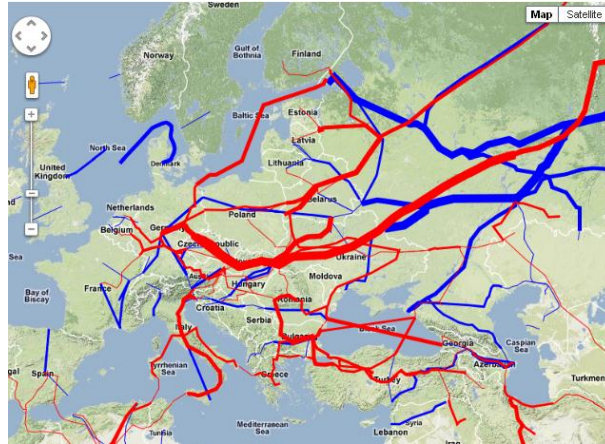

08.11.2011

BIBERACHER, Markus; RSA [markus.biberacher@researchstudio.at]
EDER, Tobias; IPP [tobias.eder@ipp.mpg.de]

Slide 15

Spatial data in energy system models



EFDA TIMES IRE processes and national uranium resources in GDB

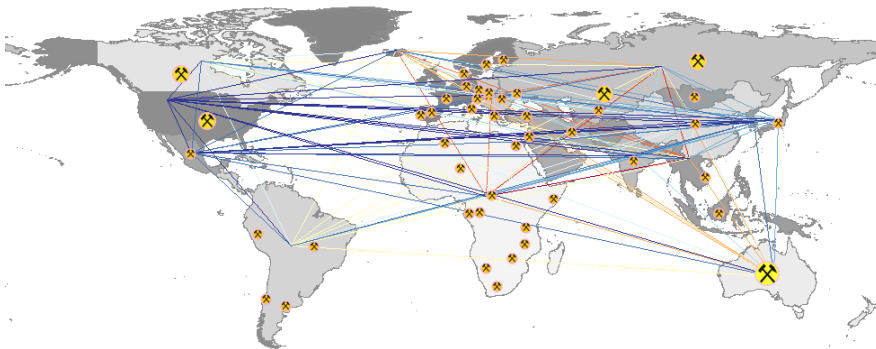

08.11.2011

BIBERACHER, Markus; RSA [markus.biberacher@researchstudio.at]
EDER, Tobias; IPP [tobias.eder@ipp.mpg.de]

Slide 16

Spatial model's structure

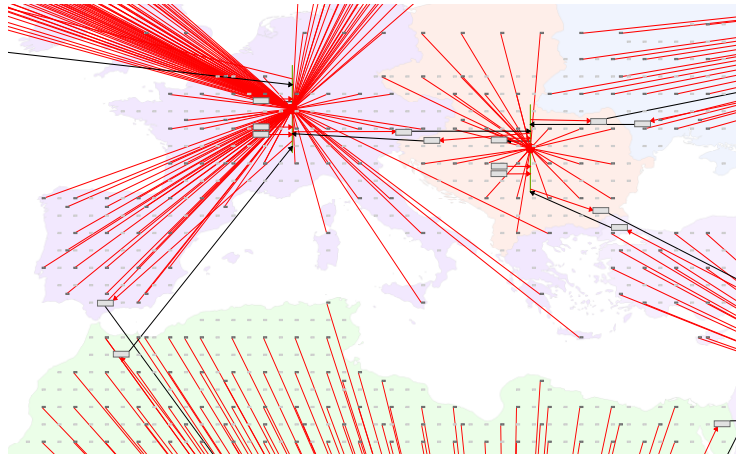

08.11.2011

BIBERACHER, Markus; RSA [markus.biberacher@researchstudio.at]
EDER, Tobias; IPP [tobias.eder@ipp.mpg.de]

Slide 17

GIS and TIMES



TIMES models	GIS models
partial equilibrium model	static, data driven real world model
forecast of the energy system development for the next decades	georeferenced datasets are processed and interpreted (snapshot)
bottom-up (technology based) model	spatial snap-shot scenarios at a certain moment
development of REGIONS in the context of the entire energy system regarding the share of certain technologies at certain future timesteps to meet the prospected demand	spatial correlations between locations, areas, corridor trails are investigated based on indicator datasets linked together by a common geo-index (geo-referenced)

08.11.2011

BIBERACHER, Markus; RSA [markus.biberacher@researchstudio.at]
EDER, Tobias; IPP [tobias.eder@ipp.mpg.de]

Slide 18